

⚠ IMPORTANT: START HERE ⚠

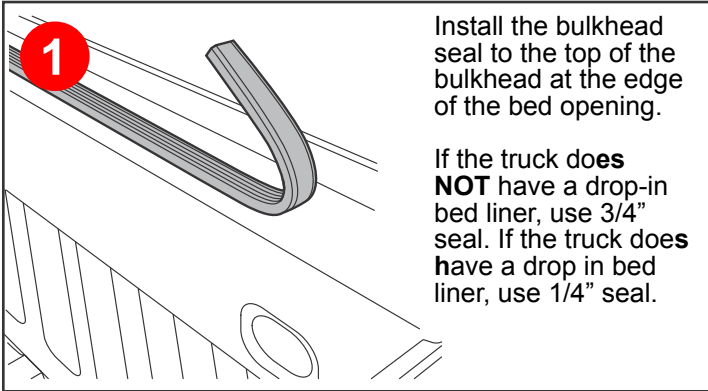

Install the bulkhead seal to the top of the bulkhead at the edge of the bed opening.

If the truck does **NOT** have a drop-in bed liner, use 3/4" seal. If the truck does have a drop in bed liner, use 1/4" seal.

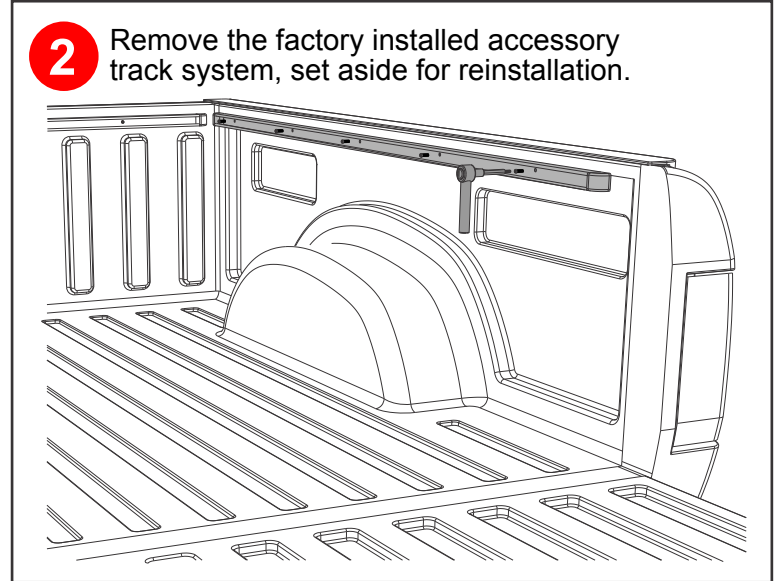

Remove the factory installed accessory track system, set aside for reinstallation.



Slide the 5 'S' clamps into the corresponding slot in the supplied Revolver rail.

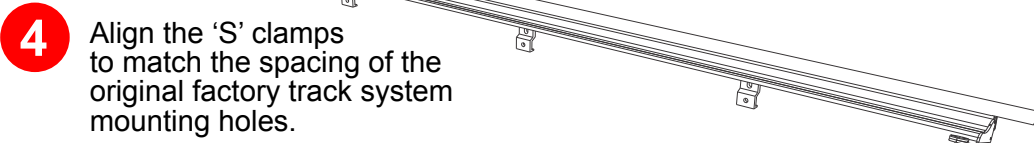

Align the 'S' clamps to match the spacing of the original factory track system mounting holes.

5 - 'S' clamps for a 5' 6" bed,
6 - 'S' clamps for a 6' 6" bed.

5 Mount the supplied Revolver rail into the original factory mounting holes using the supplied Torx screws through the middle slot of the 'S' clamps.

Align the rail with the front/cab bulkhead, per Step 5A, tighten the screws.

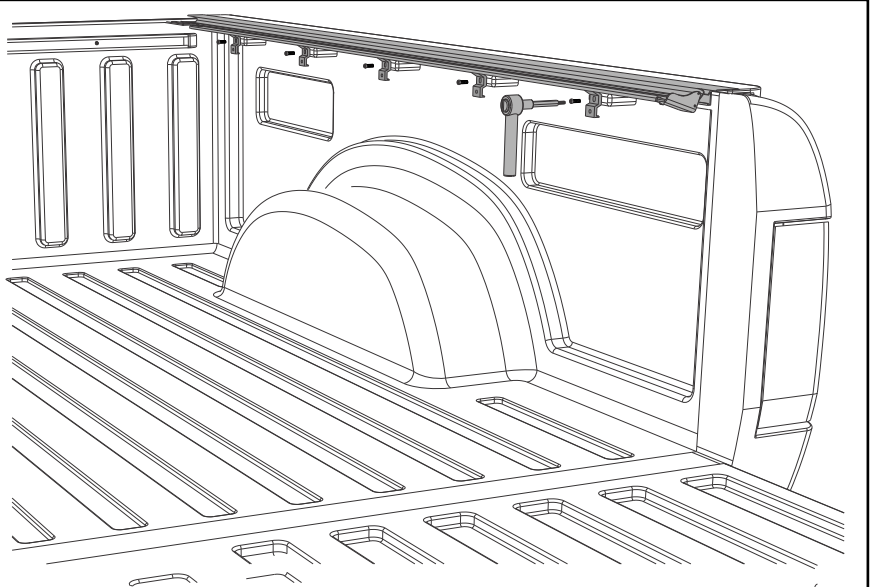
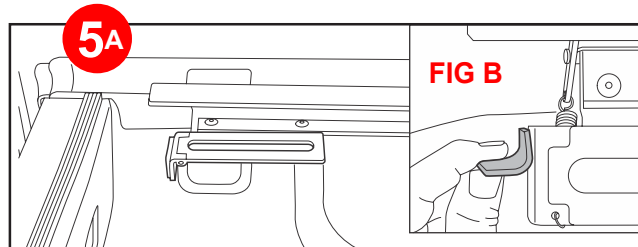
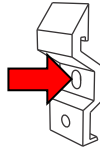

Position the rail with the silver, slotted bracket all the way forward, towards the cab, front of the vehicle.

If the truck is equipped with a drop-in bed liner, remove the foam pad located on the end of the slotted bracket as shown in FIG B.

6 Remount the factory track system using the original hardware into the threaded holes at the bottom of the 'S' clamps.

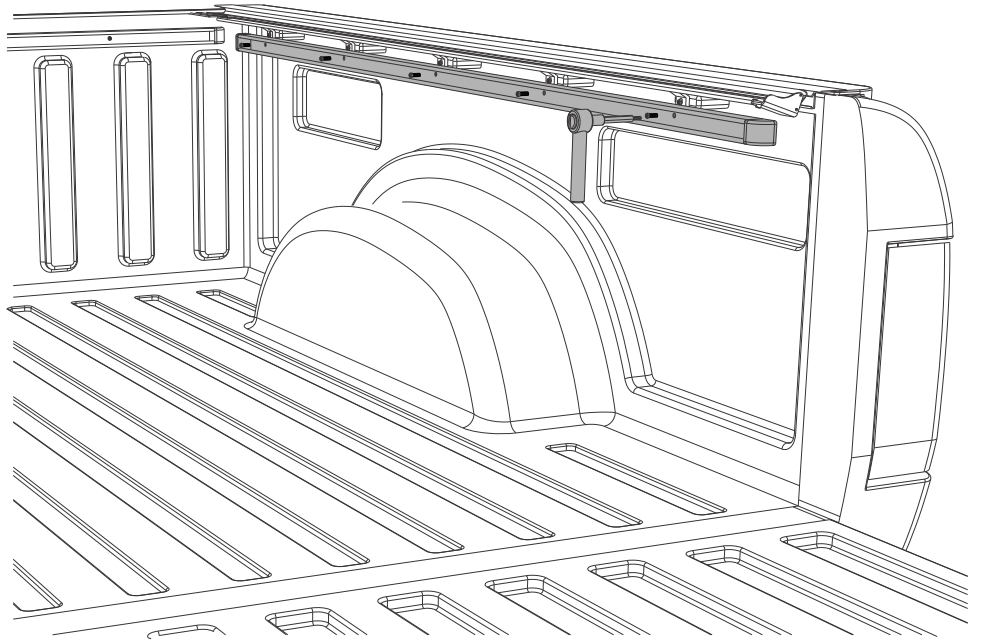
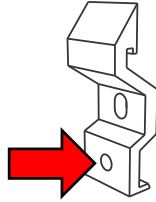

7 Remove the end cap from the factory accessory track system. Then slide the buckle strap bracket into the rail. Replace the end cap.

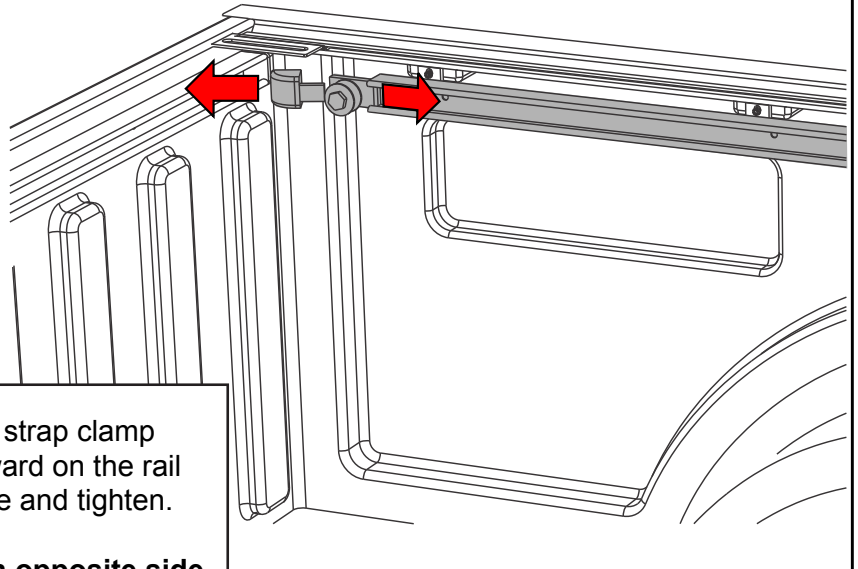

Mount the strap clamp as far forward on the rail as possible and tighten.

Repeat on opposite side.

← Forward, cab end

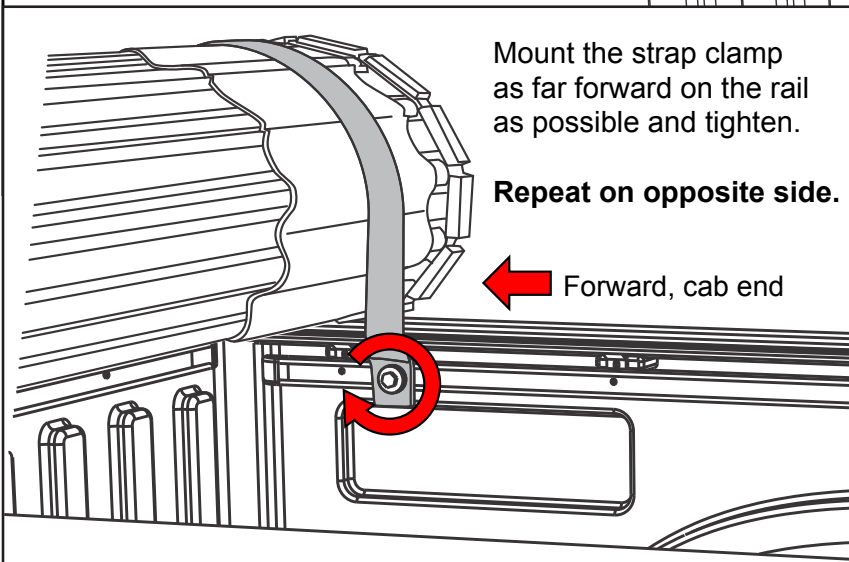

Return to standard Installation Sheet, Step 8