

**Any damaged or missing parts?**

Parts will be shipped to you directly.  
Call 818-365-9000 Mon - Fri 8:30 am - 6:00 pm EST  
or email support@bakindustries.com

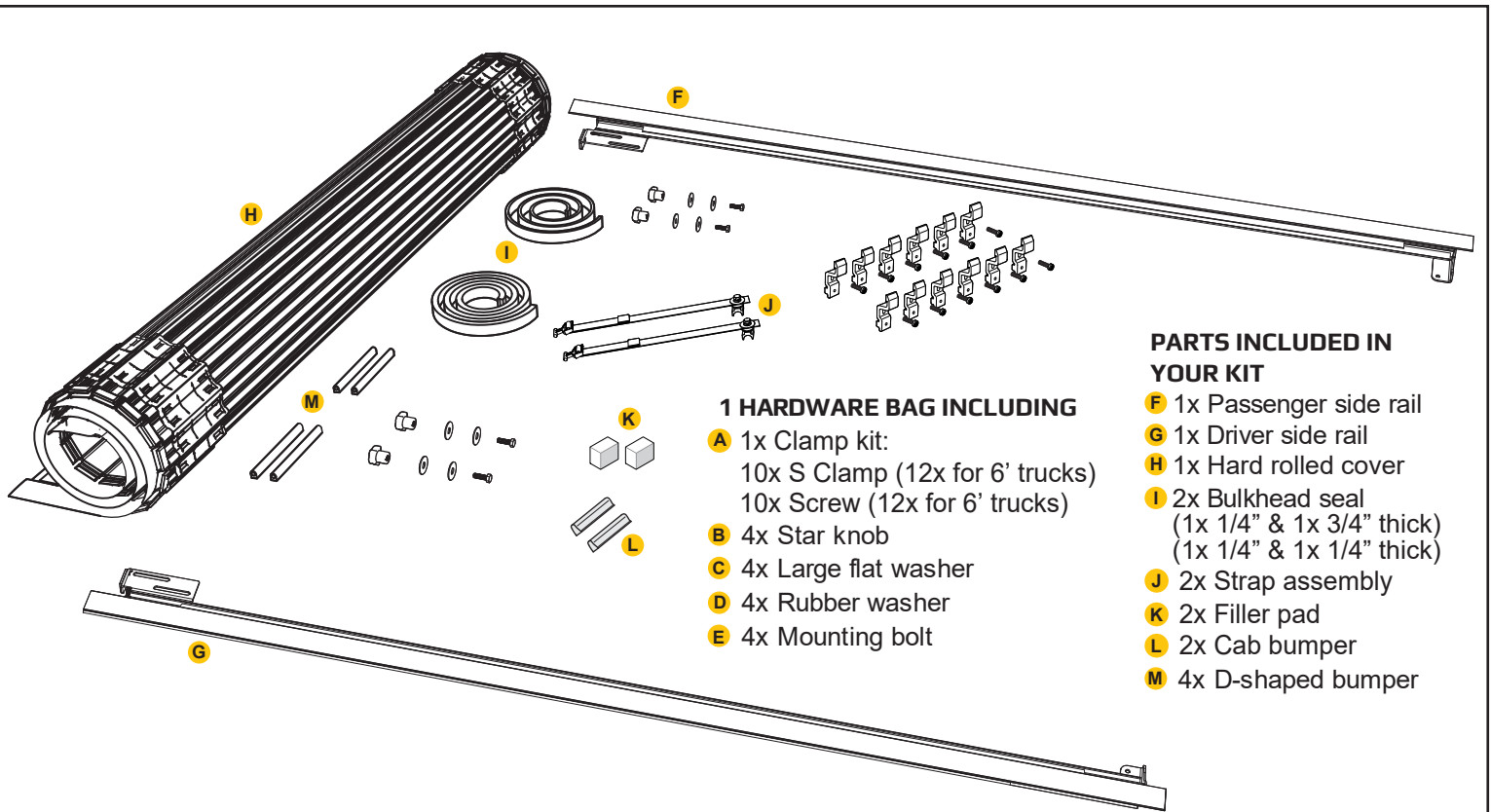

**PARTS INCLUDED IN YOUR KIT**

- F** 1x Passenger side rail
- G** 1x Driver side rail
- H** 1x Hard rolled cover
- I** 2x Bulkhead seal (1x 1/4" & 1x 3/4" thick) (1x 1/4" & 1x 1/4" thick)
- J** 2x Strap assembly
- K** 2x Filler pad
- L** 2x Cab bumper
- M** 4x D-shaped bumper

**1 HARDWARE BAG INCLUDING**

- A** 1x Clamp kit:  
10x S Clamp (12x for 6' trucks)  
10x Screw (12x for 6' trucks)
- B** 4x Star knob
- C** 4x Large flat washer
- D** 4x Rubber washer
- E** 4x Mounting bolt

**TOOLS REQUIRED**

- Scissors or utility knife
- T-30 Torx socket
- Drill or socket wrench

**TOOLS RECOMMENDED**

- Blow dryer or heat gun

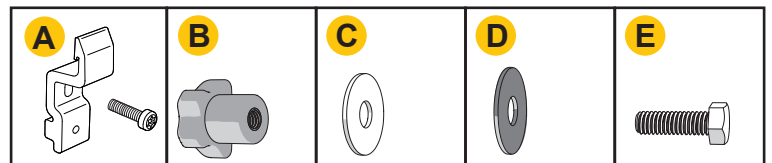

**1a** IF CARGO RAIL IS PRESENT - Remove the cargo rail fasteners using a drill/socket wrench and then the rail. Keep both for later reinstallation.

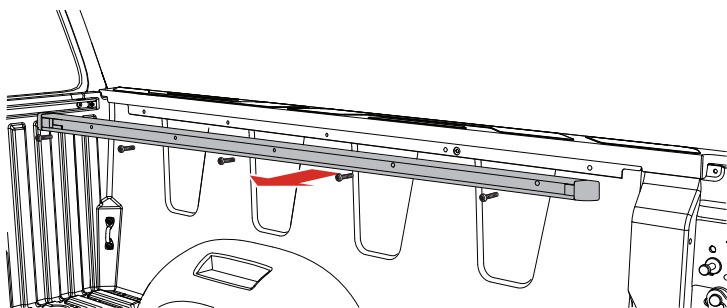

**1b** IF CARGO RAIL IS NOT PRESENT - Remove the fasteners using a drill/socket wrench and keep for later reinstallation.

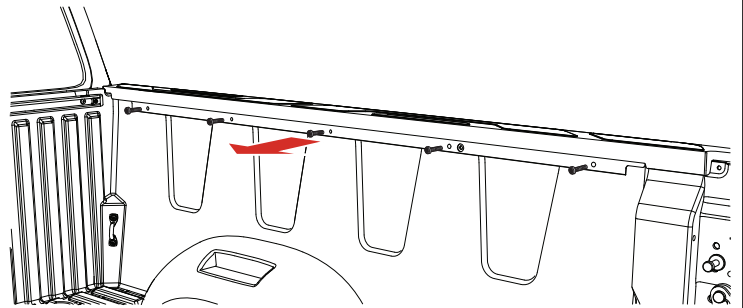

- 2** **A.** Install foam block filler pad (K), with adhesive end up, as far forward as possible against the cab end bed wall/bulkhead. **B.** Then push upward into place as far as possible. Do this for both passenger and driver sides.

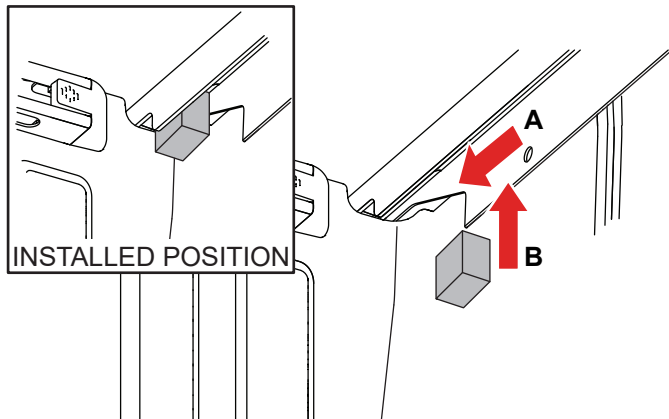

- 3** Take the cab bumper (L) and remove the backing. Place it in the bulkhead valley as shown.

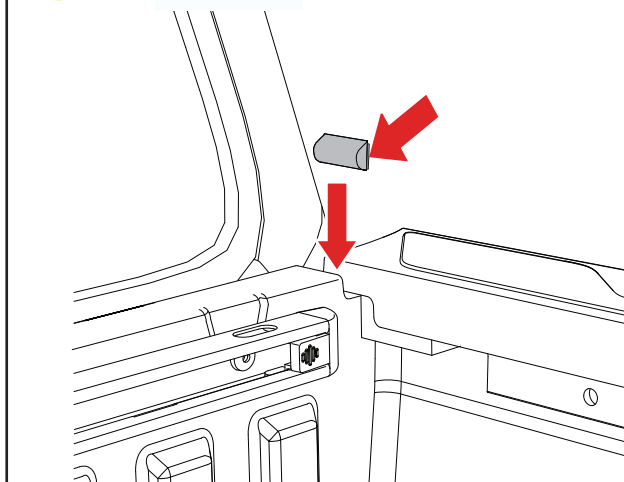

- 4** Align the S clamps from the clamp kit (A) with the passenger side rail slot and insert into the rail. The S clamps should match the truck bed hole locations used in step 1.

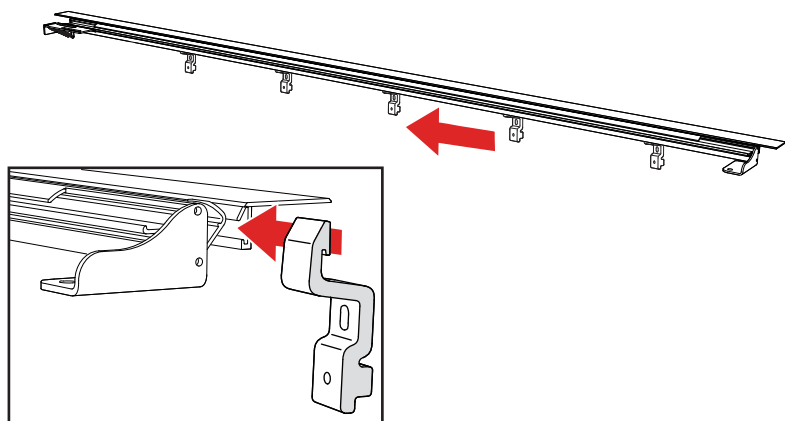

- 5** Mount the passenger side rail (F) into the holes in the truck bed used in step 1. Reuse the fasteners from step 1, using a drill/socket wrench. Before tightening, make the necessary adjustments for the rail so that it has proper clearance to both the front cargo rail and the tailgate. Make sure the passenger side rail is pushed tight up against the front cargo rail.

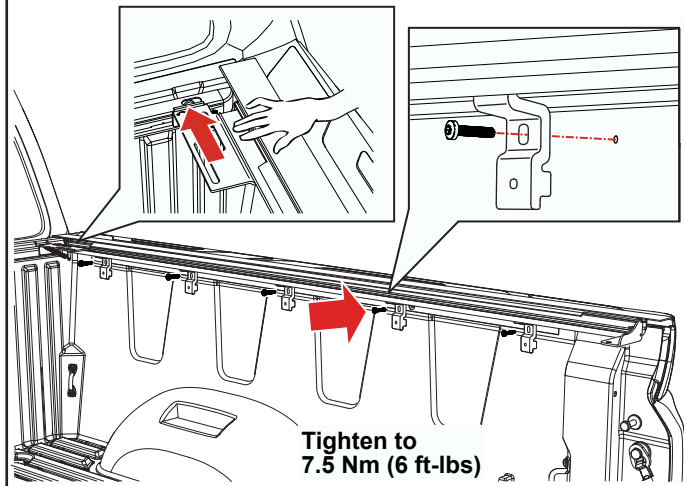

- 6** If **NO** cargo rail is present, disassemble the strap assembly (J) and use only the strap, washer and lock washer. Use the torx screw from the clamp kit (A). Secure the strap, washer, lock washer and torx screw to the first S clamp near the cab end.

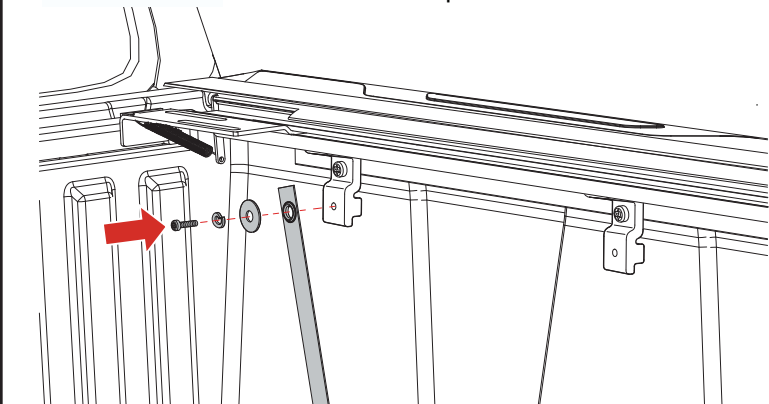

- 7** If cargo rail is present, mount it using the clamp kit (A) screws and a drill/socket wrench, through the lower hole in the S clamp. **Tighten to 7.5 Nm (6 ft-lbs).**

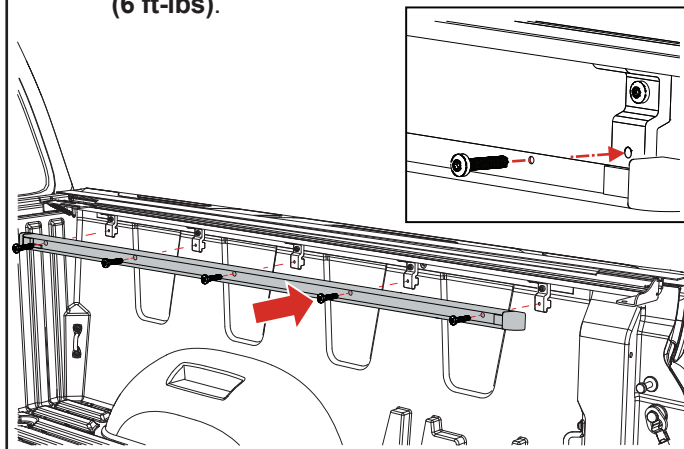

- 8** If cargo rail is present, remove the tab near the cab end of the rail.

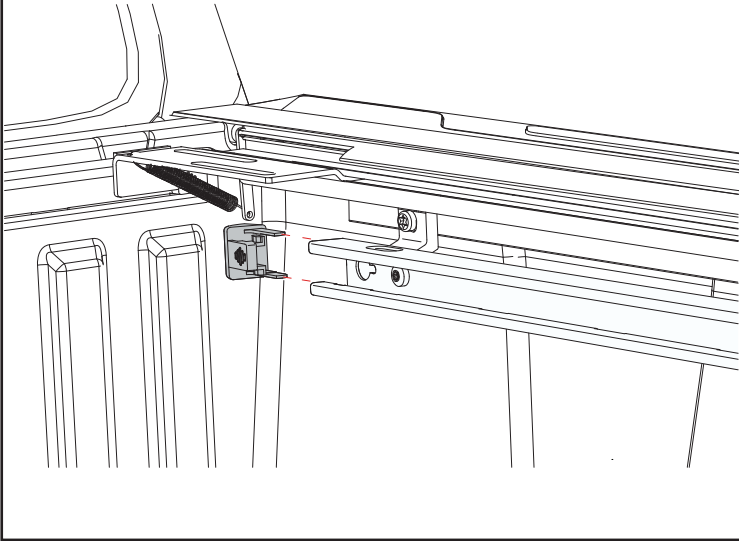

- 9** If cargo rail is present: **A.** Slide the T-nut, a part of the strap assembly (J), into the cargo rail at the cab end. **B.** Then attach the rest of the strap assembly - the bolt, lock washer, washer, strap, and flat washer to the T-nut. Place strap assembly about 6" in (152.4mm) from the cab end and tighten, adjusting the position of the strap as desired. Repeat steps 1-9 on the driver's side with the driver's side rail (G).

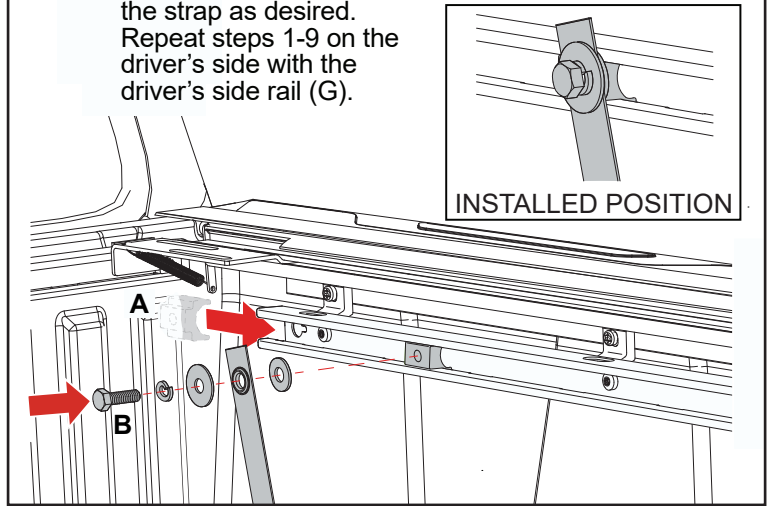

- 10** Clean the top of the bulkhead to install the bulkhead seal (I). Peel the backing off and adhere the seal from one bedrail edge to the other. Remove any excess with a scissors or a utility knife. If the truck has a drop-in bedliner, no seal will be needed.

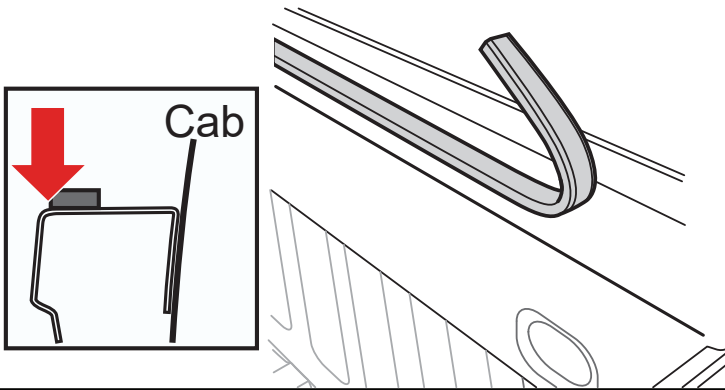

- 11** With both rails clamped in place, rest the hard rolled cover (H) onto the rails at the tailgate, roll the cover toward the cab, and remove and discard all packaging materials.

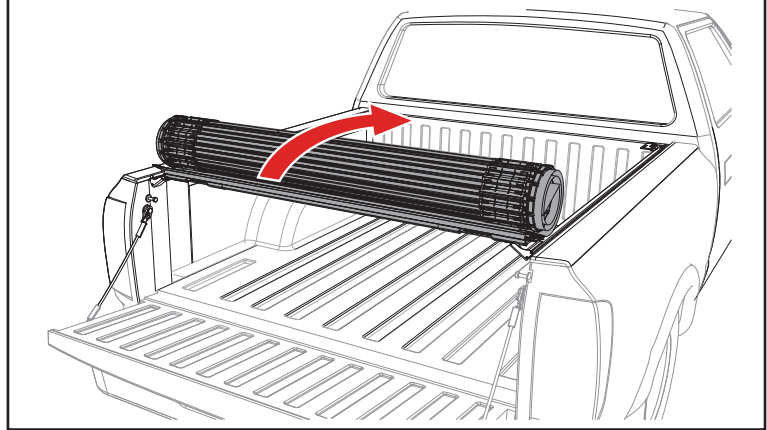

- 12** Roll the hard rolled cover (H) forward toward the cab, fold the front panel back and insert the two mounting bolts (E) into the slotted bracket. Do this for both sides. The bolts will align with the side rail bracket holes. Fold the panel back down.

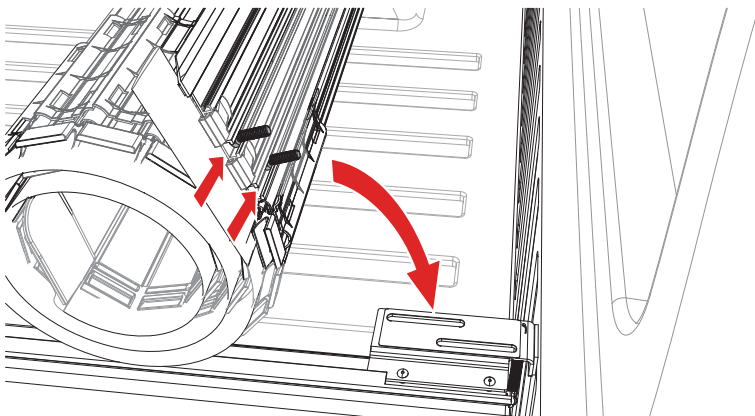

**Note:** Remove all foam packing before proceeding.

- 13** Install the mounting hardware **loosely** underneath the slotted bracket on the passenger side rail (F). Start with the rubber washer (D), then the large flat washer (C), then hand tighten the star knobs (B). Repeat on the driver's side. Leave the star knobs loose for now.

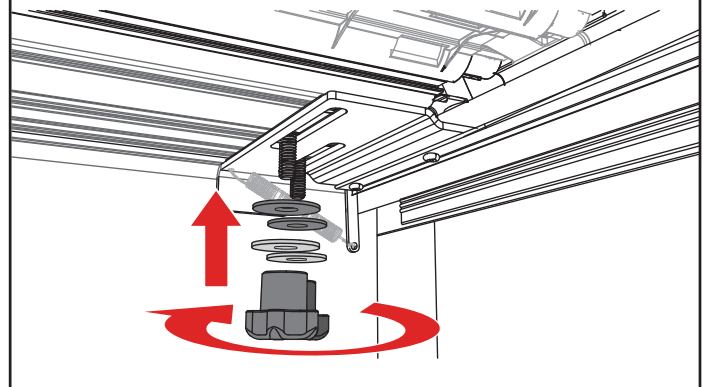

- 14** Open and close the hard rolled cover (H) several times to verify that it rolls freely. The cover should be square with the side rails and roll freely between the side rails.

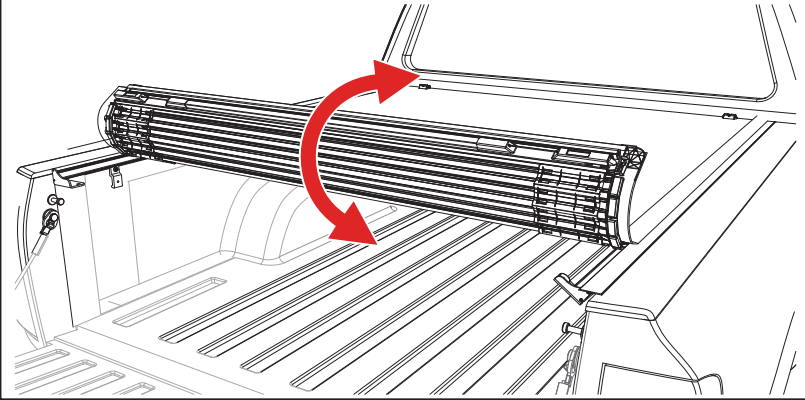

- 15** Align the front vinyl edge of the hard rolled cover (H) with the front edge of the side rails (not the rubber seal).

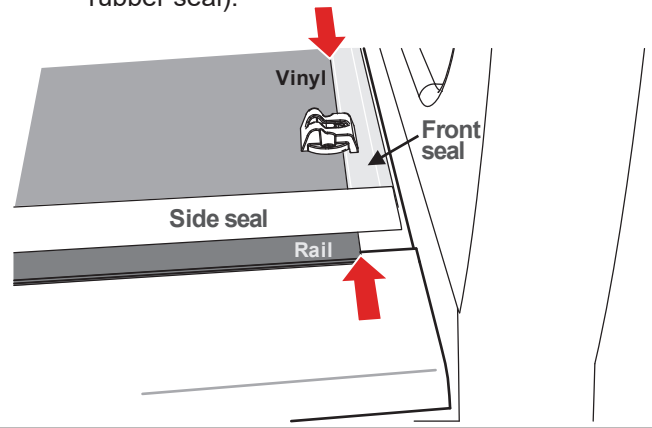

- 16** Verify that a gap of approximately 1/8" (3.2mm) remains on both sides of the hard rolled cover (H) between the edge of the side rail and the hard rolled cover. This spacing is necessary to ensure that the locking side rail secures to the cover. Align the hard rolled cover side to side at the front and/or the back if the side gaps are not even. Firmly hand tighten the star knobs (B) after the hard rolled cover has been aligned.

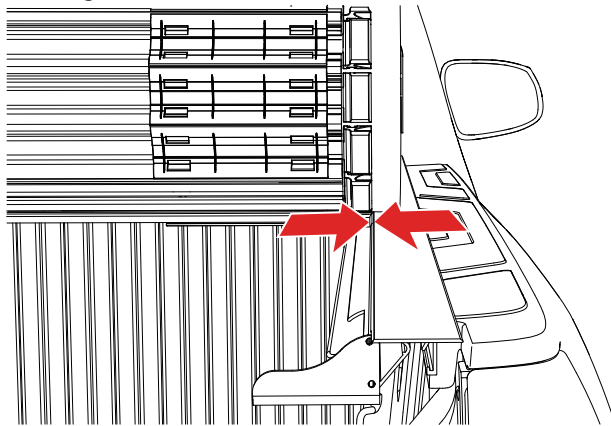

- 17** When correctly installed, the vinyl edges of the hard rolled cover (H) will align squarely with the side rails in all four corners. The latch assembly will align with the side rail locking levers at the tailgate on both sides.

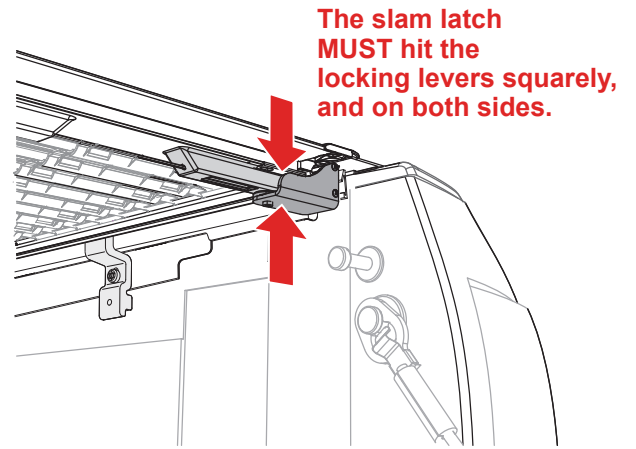

- 18** Check to see that the latches on both sides at the tailgate fully engage the side rails. Loosening the star knobs (B) and making the side to side adjustment as in step 16 could help with the latch striker engagement.

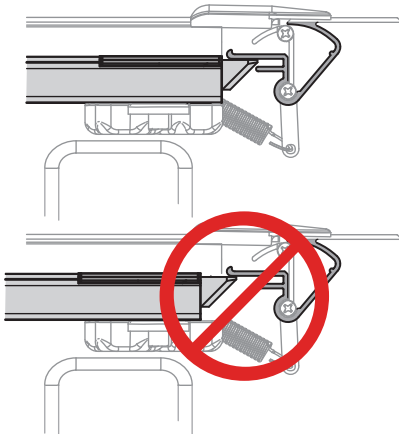

- 19** When the cover is properly aligned, roll the cover open, ensuring not to misalign while opening, tighten the star knobs (B) on both sides to secure the cover. **DO NOT overtighten.** Hand tighten only. Recheck that the hard rolled cover (H) operates correctly. Close the cover and check that the locking levers are engaged and prevent the hard rolled cover from being lifted on both sides.

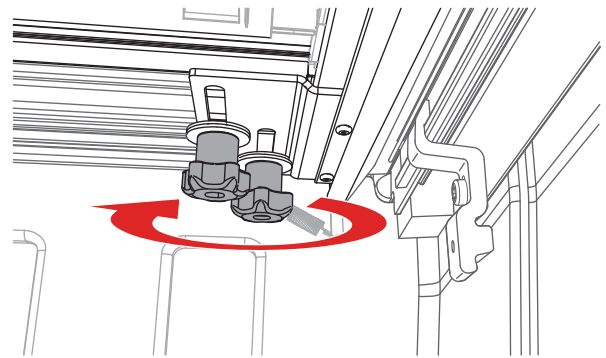

**20** The end of the strap inserts into the hard rolled cover (H) clasp and turns to lock.

Pull up on the strap end to tighten.

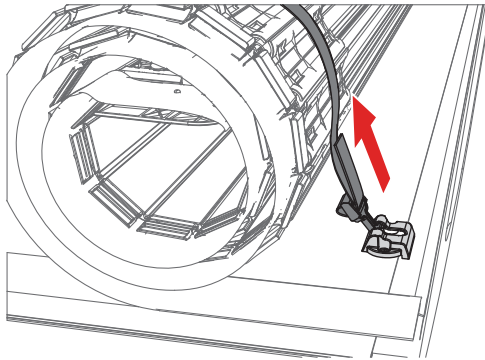
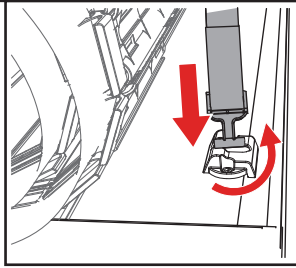

**Always hook the straps on BOTH sides.**

**21** With the hard rolled cover (H) rolled open, remove the paper backing from the D-shaped bumpers (M), clean the surfaces where they touch the cover, and adhere the bumpers to the cover slats. Position the D-shaped bumpers so that they prevent the hard rolled cover from contacting the cab. The straps will secure the hard rolled cover away from the cab and glass.

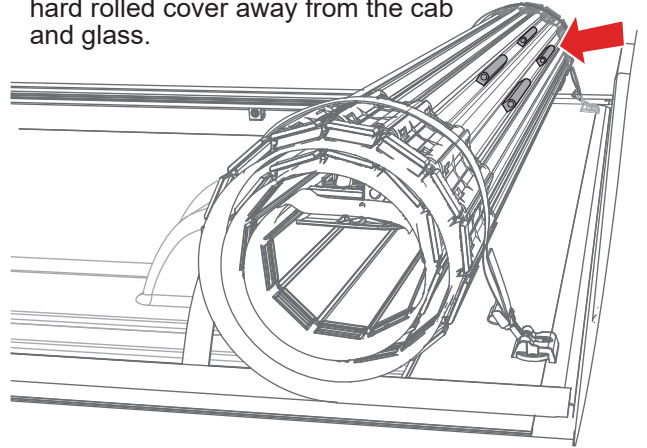

**22** If the side seals of the hard rolled cover (H) appear wrinkled, exposure to the sun will assist the seals to lay flat. Applying heat with a hair dryer or carefully with a heat gun will also smooth the seals.

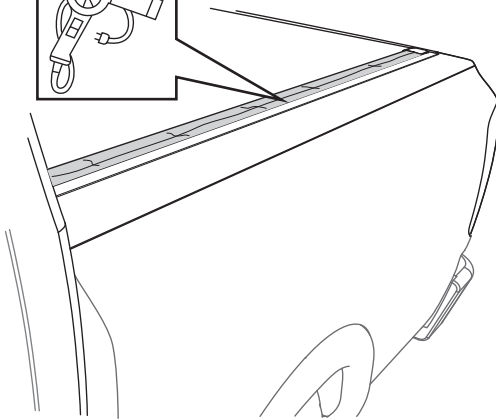
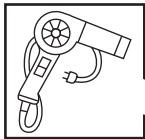

# IMPORTANT Safe operation and use

## IMPORTANT NOTICE

While driving, cover must be completely flat and secure with BOTH rear latches engaged and in the closed position OR completely rolled up and secured at the cab with the provided straps.  
**DO NOT DRIVE with cover partially opened.**

### Truck Bed Cover Positions While Operating Vehicle

Prior to vehicle operation, the truck bed cover MUST be properly secured.

#### CLOSED POSITION (FIG 1)

Cover must be closed and **FULLY LATCHED ON BOTH SIDES** of the cover side rails.

#### OPEN POSITION (FIG 2)

To drive with the cover in the open position, use the strap clamps. Roll the cover forward, twist and insert the clips into the cover clasps. Ensure that **BOTH** strap clamps are fully inserted into the clasps, pull on the end of the strap to tighten.

### Cover Operation

#### TO CLOSE THE COVER (FIG 3)

Roll the top toward the tailgate and rotate the tail rail downwards towards the rotating locking levers.

**WARNING** – When closing the cover ensure rear latches on **BOTH** sides are fully engaged underneath the cover rails before operating the vehicle.

#### TO OPEN THE COVER (FIG 4)

Pull down on the latch release cable located on either side of the cover and rotate the tail rail forward and into a rolling motion. When driving with the cover open, the cover must be rolled toward the cab and secured with both strap clamps.

**DO NOT ATTEMPT TO DRIVE WITH THE COVER IN THE PARTIALLY OPEN POSITION!**

#### ADDITIONAL IMPORTANT OPERATING TIPS

- Truck bed cover MUST be free of foreign material including snow and ice before opening rail top.
- Do NOT tow your vehicle from the rear with the tonneau on your truck.
- Do NOT operate vehicle with objects on top of cover.

**FAILURE TO FOLLOW THESE CAUTIONS MAY RESULT IN SEVERE DAMAGE AND WILL VOID YOUR WARRANTY!**



Remove all foreign matter before rolling the cover.



Do NOT tow your vehicle from the rear with this cover on your truck.

Fig. 1  
Closed position

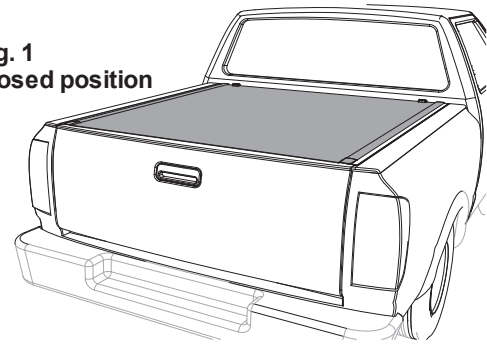

Fig. 2  
Open position

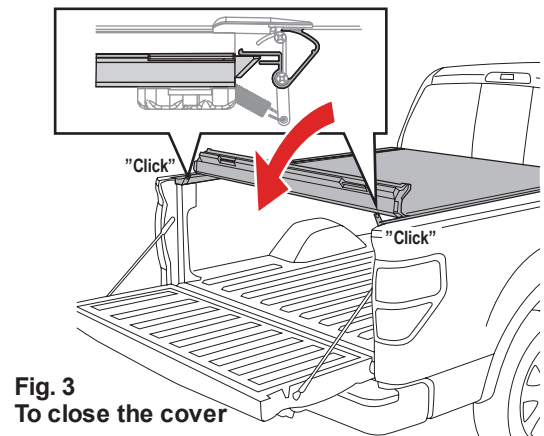
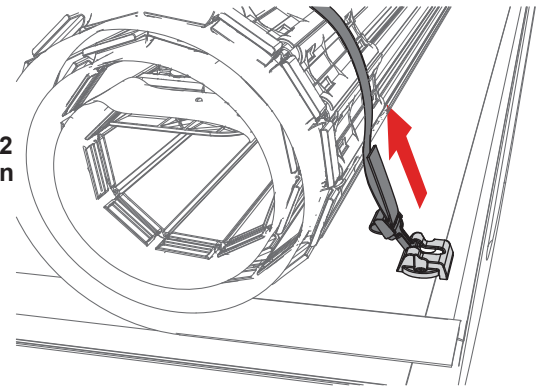
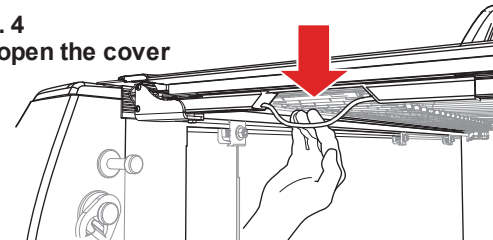

Fig. 3  
To close the cover

Fig. 4  
To open the cover



# LIMITED WARRANTY

## WARRANTY COVERAGE

This truck bed cover is warranted against defects in materials or workmanship as follows. This warranty is void if the product has been damaged in an accident, or due to neglect, unforeseeable use, improper installation, improper servicing, or other cause not arising out of defects in material or workmanship.

**Revolver X2** - The truck bed cover carries a limited warranty for **five (3) years** from the original date of purchase, subject to the terms below.

**Revolver X4s** - The truck bed cover carries a limited warranty for **three (5) years** from the original date of purchase, subject to the terms below.

## WARRANTY IS NOT TRANSFERABLE

The warranty is to the initial owner purchasing the truck bed cover and it is not transferrable to a subsequent end user. Proof of purchase may be required to enforce these warranty rights.

## WARRANTY CONDITIONS

Failure to follow care and use instructions will void the warranty.

- Clean with mild automotive soap and water only.
- Cover must be secured at all points when vehicle is in motion.
- Check all clamps and retention mechanisms for tightness after a week of driving following installation (or re-installation) of the cover and periodically thereafter.
- Before opening, the cover must be free of all foreign materials including snow and ice.
- Do NOT tow your vehicle from the rear with the cover on your vehicle. If towing from the rear is required, the cover MUST be removed from the vehicle and properly stored.

## WARRANTY PERFORMANCE

If all warranty conditions are met, a defective truck bed cover or hardware component will either be repaired or replaced (at our option). We reserve the right, for any warranty, to substitute a newer model or bed cover having similar form and function, to offer a warranty discount on an entire replacement system, and/or provide remedies other than those mentioned in this document.

## WARRANTY RETURN

A Return Material Authorization number must be obtained from our Customer Service Department prior to returning any product. We may require the original item to be returned postage prepaid for final determination. Shipping charges will apply for any repair or replacement. Other than postage or shipping charges, no charge will be made for repair or replacement under this warranty.

This warranty gives you specific legal rights. As an owner, you may also have additional rights and remedies under the laws of your state.

## WARRANTY REGISTRATION

Warranty registration must be on file and/or proof of original purchase (detailed and dated receipt) required for warranty to be effective.

<https://realtruck.com/bak-warranty>

**REGISTER  
YOUR  
WARRANTY  
ONLINE**



## CARE AND MAINTENANCE

Revolver tonneaus are made from durable materials and require simple care to ensure a long life of performing well and looking great.

### **Cleaning the Top (Washing)**

Standard automotive soap and water with a soft sponge or cloth are recommended for cleaning. Shammy dry to keep the finish polished and brilliant. Wax is NOT recommended as it tends to fill in cracks and crevices, which may affect the textured panel finish. Do NOT use any harsh cleaners or abrasives.

### **Maintenance**

It is recommended that you periodically check your cover is securely attached to your truck bed. Inspect the clamps and front mounting bolts to ensure they were properly installed and have not come loose or knocked out of adjustment during operation. Covers that are used with high frequency or that are subject to the vibrations and impact from rough roadways can cause the cover to require adjustment.

### **Lubricating the Latches**

It is recommended that you periodically inspect and service the latches on each panel. Clean away any excess dirt or grime and lubricate with silicone spray. Ensure the latches move freely in and out to properly engage the side rail and provide proper performance with optimum security. Be careful not to overspray the cover. Wipe away any excess around the latch location.